

# SBM-XS 300 G1E1

# LISSMAC

METAL PROCESSING

DEBURRING AND EDGE ROUNDING ON BOTH SIDES OF SMALL COMPONENTS IN ONE OPERATION

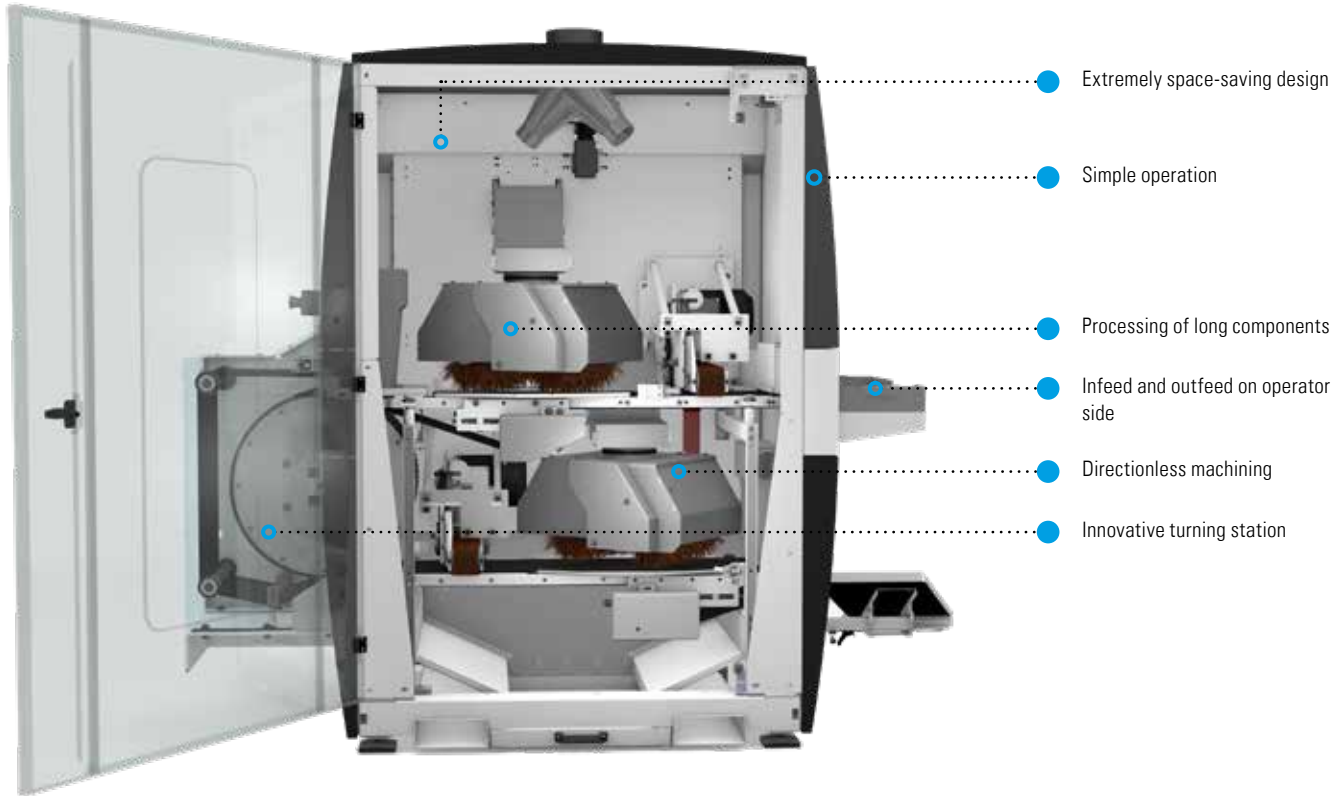

Extremely space-saving design

Simple operation

Processing of long components

Infeed and outfeed on operator side

Directionless machining

Innovative turning station

FURTHER INFORMATION:



TECHNICAL DATA	SBM-XS 300 G1E1	SBM-XS 300 G1E1 ALU MIX
Working width max.	300 mm	300 mm
Workable material thickness	1 - 15 mm	1 - 15 mm
Voltage	400 V, 50 Hz / 480 V, 60 Hz	400 V, 50 Hz / 480 V, 60 Hz
Network structure	3~ PEN / 3~ PE+N	3~ PEN / 3~ PE+N
Total current consumption	13.5 A / 14 A	24 A / 23 A
Total power	7.5 kW / 8.5 kW	14 kW / 15.2 kW
Insulation class	IP 42	IP 42
Infinitely variable feed speed	0 - 2 m/min	0 - 2 m/min
Weight approx.	1400 kg	1450 kg
Dimensions (W/D/H)	1300/2300/1900 mm	1300/2300/1900 mm

- With a magnetic table designed for part dimensions of 25 x 25 x 1 mm up to maximum 200 x 200 x 15 mm (geometry-dependent)
- With vacuum table for part dimensions of 45 x 45 x 1 mm up to maximum 200 x 200 x 15 mm (geometry-dependent)
- Time consuming turn-over of parts with a second pass is not necessary
- Swinging away of the innovative turning station makes it possible to deburr parts longer than 200 mm
- A higher level of automation ensures an economic and reliable deburring process, also for large quantities of parts
- A high and sustainable deburring quality.
- Dry deburring process (no chemical additives as used in tumblers)
- Small parts are returned to the front of the machine and gathered in a box. No extra walking back and forth for the operator.
- Energy-efficient
- The deburring process ensures an even wear of the belt and brushes across the entire width of the machine
- Fast and simple tool Change
- Simple and intuitive operation of the machine
- Modern, compact machine design



before



after

#### OPTIONS



[ 1 ] Parts slide

[ 2 ] Table extension